

Emerald Series (24K-72K) Condensers

Innovative Chassis Conquers Installation Challenges



After listening to boat builders, global service teams and boat owners, Dometic engineers designed the innovative Emerald Condenser series to harness and maximize the impressive performance of R-410A refrigerant while meeting all international clean air standards.

The compact design of the Emerald series incorporates built-in vibration-isolating mounts, two large drain connections and numerous mounting options for installation to a smooth deck, stringer or existing rack. The incorporated lifting handles and smooth bottom allows for easy lifting and quick placement of the unit. The molded composite no-rust drain pan is shaped to provide positive drainage even when the boat heaves and rolls. The amount of standing water in the drain pan is reduced by up to 85%, which is 8x times less than a typical drain pan.

Emerald condensers can be installed quickly and easily. The drain, seawater and refrigerant connections are conveniently located to conquer installation challenges thus reducing installation time by up to fifteen minutes. The electrical box can be easily removed and located up to 5 ft. (1.5 m) away, further reducing the size of the unit while making the system more accessible. The reversing valve, pressure switches and service ports are centrally located, high on the unit for access from any side.



The reversing valve, pressure switches, and service ports are centrally located for easy maintenance access from any side.



Vibration-isolating compressor mounting system reduces noise and vibration.

Key Benefits

- Up to 85% reduction in standing water in the drain pan
- Up to 15 minutes faster to install
- Square chassis for easy installation in tight spaces
- Three mounting options adapt to installation environments
- Rust-free composite drain pan
- Reconfigurable chassis allows optimal drain connections
- Compressor vibration-isolation mounts minimize noise and vibration
- Built-in refrigerant line filter drier reduces installation time and protects the compressor from moisture and contaminants
- Reversing valve, pressure switches, and service ports centrally located for easy maintenance access from any side
- Engineered to maximize the performance of R-410A, an environmentally safe refrigerant

Cruisair[®]

by Dometic GROUP

Specifications for Emerald Series (24K-72K) Condensers

Model (1)	E*24	E*30	E*36	E*48	E*60
Capacity (BTU/h) (2)	24000	30000	36000	48000	60000
Voltage (V)	230	230	240	230	230
Cycle (Hz) (3) / Phase (Ph)	60/1	60/1	60/3	60/1	60/1
Full Load Amps (FLA) Cool (A)	6.3	7.3	9.1	11.9	13.56
Full Load Amps (FLA) Heat (A)	7.8	9.2	11.5	15.8	20.15
Locked Rotor Amps (LRA) (A)	43	54	67	105	150
Max. Circuit Breaker (A)	30	15	20	75	80
Min. Circuit Ampacity (A)	17	14	22	43	48
Refrigerant Type	410A	410A	410A	410A	410A
Max. Height (in/mm) (4)	18/458	18/458	18/458	18.5/470	20/508
Width (in/mm) (4)	16/407	16/407	16/407	16/407	16/407
Depth-Without Elec. Box (in/mm) (4)	16/407	16/407	16/407	16/407	16/407
Depth-With Elec. Box (in/mm) (4)	18.8/478	18.8/478	18.8/478	18.8/478	18.8/478
Seawater Inlet Connection (in/mm)	5/16	5/16	5/16	5/16	5/16
Seawater Connection Type	cupranickle tube	cupranickle tube	cupranickle tube	cupranickle tube	cupranickle tube
Refrigerant Line Connection-Discharge (in)	3/8	3/8	3/8	3/8	3/8
Refrigerant Line Connection-Suction (in)	3/4	3/4	3/4	3/4	3/4
Net Weight (lbs/kg) (5)	98.5/44.7	104/47.2	100/45.4	114.5/51.1	122/55.4
Gross Weight (lbs/kg) (5)	129/58.6	133/60.4	132/59.9	147/66.7	153/69.4
Height-Electrical Box (in/mm)	13.25/337	13.25/337	13.25/337	13.25/337	13.25/337
Width-Electrical Box (in/mm)	7.75/197	7.75/197	7.75/197	7.75/197	7.75/197
Depth-Electrical Box (in/mm)	3.75/96	3.75/96	3.75/96	3.75/96	3.75/96

1 Cruise air customers, replace "in" in the model name with "Q" for Q-Logic digital control system, or "W" for electro-mechanical control. Marine Air customers, replace "in" in the model name with "D" for Passport I/O digital control system, or "M" for electro-mechanical control.
 2 BTU and electrical data are based on +45°F/7.2°C evaporator and 100°F/37.8°C condenser in cool mode, and a +45°F/7.2°C evaporator and 130°F/54.4°C condenser in heat mode.
 3 60Hz units must not operate at 50Hz and 50Hz units must not operate at 60Hz unless data plate says otherwise.
 4 All dimensions ± 0.30 in. (8 mm).
 5 All weights ± 10%.

Dimensions

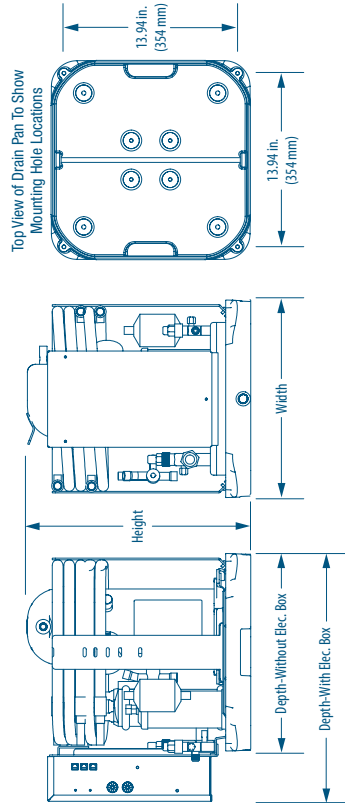

DOMETIC MARINE DIVISION

2000 N. Andrews Ave. Ext. | Pompano Beach, FL 33069 USA | Tel. 954-973-2477 | Fax: 954-979-4414
 www.Dometic.com/Marine | MarineSales@DometicUSA.com

24/7 TECH SUPPORT FOR UNITED STATES & CANADA:

8:00 AM to 5:00 PM Eastern Time: 800-542-2477
 After hours and weekends: 888-440-4494

INTERNATIONAL SALES & SERVICES

Europe & the Middle East: Call +44(0)870-330-6101
 For all other areas visit our website to find your nearest distributor.

L-2702B Rev. 20140509

Specifications and availability subject to change without notice.

Dealer

